



New: Green Pin® ROV Shank Hook

The Green Pin® ROV Shank Hook E is a grade 8 eye hook with a long shank which has been developed for release and retrieve sub-sea operations with a remotely operated vehicle (ROV). Attached to the body and latch of the hook is a wire rope that can be grabbed with an ROV arm. This enables the ROV operator to easily manipulate the latch and thereby to swiftly open and close the hook. The hexagonal shape of the shank makes it easy to grab the hook.

The design of the hook and the smooth powder coated finish reduces wear on lifting slings. The ROV shank hook is equipped with a safety latch, which is fitted with a stainless-steel spring and which can be locked with a split pin. The hook tip extension keeps the latch in place, which guarantees full safety and makes aiming, steering and hooking up easier.

The white coating of the Green Pin® ROV Shank Hook optimizes visibility under water and ensures its long-term durability. The ROV shank hook is available in a range with a working load limit from 12 up to 80 tons.

greenpin.com

A VAN BEEST BRAND

Product update

August 2021

Green Pin® ROV Shank Hook E GR8

Product code: P-6740
Material: alloy steel, Grade 8, quenched and tempered
Safety Factor: MBL equals 4 x WLL
Finish: painted white

Certification:

2.1 **2.2** **3.1** **MTC^a** **MPI^b** **US^b*** **CE**

* For hooks ≥ WLL 32t

working load limit	diameter	thickness shank	thickness shank	diameter eye inside	diameter eye outside	width eye	opening hook	thickness hook	width	thickness	width	length	weight each
t	a mm	b mm	c mm	d mm	e mm	f mm	g mm	h mm	i mm	j mm	k mm	l mm	kg
12	63	47	42	40	80	55	62.5	45	58	67	53	600	10.4
16	71	56	50	45	90	65	71	53	67	80	63	650	14.7
22	80	63.4	56	55	110	80	86	60	75	90	74	682	22
32	90	73	64	60	120	90	102	67	90	110	82	812	33.6
55	125	102	90	75	150	115	111	95	118	140	112	919	70.3
80	140	115	101	90	180	135	133	106	137	175	125	1049	111

working load limit	diameter	thickness shank	thickness shank	diameter eye inside	diameter eye outside	width eye	opening hook	thickness hook	width	thickness	width	length	weight each
t	a inch	b inch	c inch	d inch	e inch	f inch	g inch	h inch	i inch	j inch	k inch	l inch	lbs
12	2 15/32	1 27/32	1 21/32	1 9/16	3 5/32	2 5/32	2 15/32	1 25/32	2 9/32	2 5/8	2 3/32	23 5/8	22.9
16	2 25/32	2 7/32	1 31/32	1 25/32	3 17/32	2 9/16	2 25/32	2 3/32	2 5/8	3 5/32	2 15/32	25 19/32	32.4
22	3 5/32	2 1/2	2 7/32	2 5/32	4 11/32	3 5/32	3 3/8	2 3/8	2 15/16	3 17/32	2 29/32	26 27/32	48.5
32	3 17/32	2 7/8	2 17/32	2 3/8	4 23/32	3 17/32	4 1/32	2 5/8	3 17/32	4 11/32	3 7/32	31 31/32	74.1
55	4 29/32	4 1/32	3 17/32	2 15/16	5 29/32	4 17/32	4 3/8	3 3/4	4 21/32	5 1/2	4 13/32	36 3/16	155.0
80	5 1/2	4 17/32	3 31/32	3 17/32	7 3/32	5 5/16	5 1/4	4 3/16	5 13/32	6 7/8	4 29/32	41 5/16	244.7

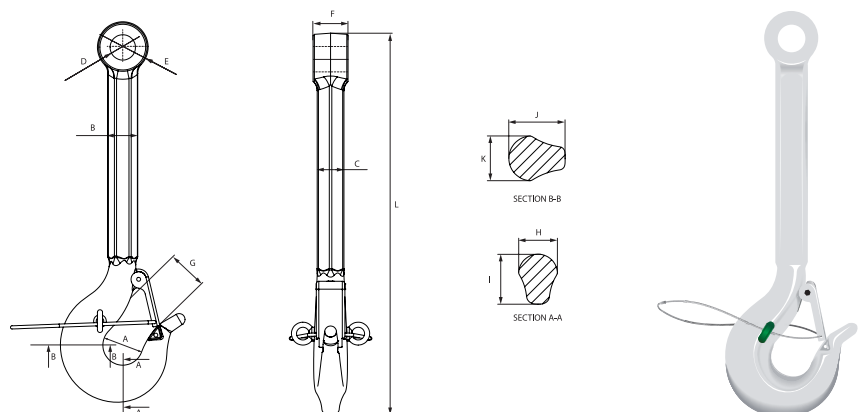

Total control, smooth operation and greater safety

- ✓ Easy to grab shape of the shank (hexagon)
- ✓ Latch can be locked by a split pin to prevent opening during operation
- ✓ Shape of hook optimized to reduce wear of ropes
- ✓ Hook tip extension makes aiming, steering and hooking up easier



greenpin.com

VAN BEEST B.V.

Head Office
Industrieweg 6
3361 HJ Sliedrecht
The Netherlands
Telephone +31 184 41 33 00
E-mail sales@vanbeest.eu

VAN BEEST GmbH

Märkische Straße 115/117
44141 Dortmund
Germany
Telephone +49 231 58 44 230
E-mail sales@vanbeest.eu

VAN BEEST FRANCE S.A.S.

Route de Chanier
63250 Celles sur Durole
France
Telephone +33 (0)4 73 51 89 51
E-mail sales@vanbeest.eu

VAN BEEST USA, L.L.C.

US main office
5615 W. Fuqua, Building B
Houston, TX 77085
United States

Chicago office
158 South Pinnacle Drive
Romeoville, IL 60446
United States

Telephone +1 713 674 57 53
E-mail sales.us@vanbeest.com

VAN BEEST DO BRASIL

Rua Alexandre Dumas, 1711, 5th Floor
Chácara Santo Antônio,
04717-004 Sao Paulo-SP Brazil
Telephone +55 (11) 2599 8364
E-mail vendas@vanbeest.com.br